

Documentation | EN

# PS9011-2440-0000

Buffer Module 24 V DC, 40 A, 160 ms





# Table of contents

<b>1 Overview .....</b>	<b>5</b>
<b>2 Foreword .....</b>	<b>6</b>
2.1 Notes on the documentation .....	6
2.2 Safety instructions .....	7
2.3 Terminology and abbreviations .....	9
<b>3 Basics .....</b>	<b>10</b>
<b>4 Technical data, application notes, wiring .....</b>	<b>12</b>
4.1 Nominal electrical values .....	12
4.2 Selection of the backup threshold voltage .....	14
4.3 Buffer storage time .....	15
4.4 Charging time .....	16
4.5 Operating diagrams .....	17
4.6 "Active" signal .....	18
4.7 "Ready" signal .....	18
4.8 Inhibit input .....	18
4.9 Efficiency and losses .....	18
4.10 Lifetime expectancy .....	19
4.11 MTBF .....	19
4.12 Functional wiring diagram .....	19
4.13 Terminals and wiring .....	20
4.14 Connection diagrams .....	20
4.15 Front side and operating elements .....	21
4.16 EMC .....	22
4.17 Environment .....	22
4.18 Protective functions and safety features .....	23
4.19 Dielectric strength .....	23
4.20 Declaration of conformity and approvals .....	24
4.21 Dimensions and weight .....	25
<b>5 Appendix .....</b>	<b>26</b>
5.1 Accessories .....	26
5.2 Documentation issue status .....	27
5.3 Support and Service .....	28



# 1 Overview

## PS9011-2440-0000 | Buffer module 24 V, 40 A, 160 ms



- Buffering with electrolytic capacitors
- Buffering of 24 V loads
- Minimum hold-up time 0.16 s at 40 A, longer hold-up time with smaller loads
- Clear status display by Status LED and signaling terminals
- Extra-large screw terminals

The PS9011-2440-0000 Buffer Module is an additional device for regulated 24 V DC power supply units that can be used for various purposes:

- Bridging of failures of the DC supply network with additional power
- Extension of the hold-up time after failure of the AC voltage.
- Short-term provision of an additional peak current that is higher than the nominal current of the power supply unit.

The buffer module uses maintenance-free electrolytic capacitors to store energy. This enables use even at ambient temperatures up to +70 °C.

The device requires no control wiring. It can be connected anywhere in parallel with the load circuit.

Buffer modules can be connected in parallel in order to increase the output current capacity or the hold-up time

### Overview of technical data \*)

Overview of technical data	PS9011-2440-0000
Supply voltage	DC24V, -20%/+25% (19.2-30 Vdc)
Required voltage for charging the capacitors	23 Vdc
Threshold voltage for buffer operation	22.5 V / V <sub>IN</sub> - 1 V (adjustable)
Buffer voltage	22.5 V / V <sub>IN</sub> - 1 V (adjustable)
Buffer current	40A
Charging duration	Typ. 34 s
Current consumption	Typically 80 mA (standby mode) Max. 600 mA (when charging)
Power loss	1.9 W (standby mode)
Buffer time	Min. 160 ms (at 22.5 V, 40 A) Min. 320 ms (at 22.5 V, 20 A) Typically 250 ms (at 22.5 V, 40 A) Typically 500 ms (at 22.5 V, 20 A) Typically 62 s (at 22.5 V, 0.1 A)
Temperature range	-25 °C to +70 °C (in operation)
Dimensions (W x H x D)	64 x 124 x 142 mm
Weight	1040 g
Markings/approvals	CE, cULus

\*) All values typical for 24 V, 40 A, +25 °C ambient temperature and after a warm-up time of five minutes, unless specified otherwise

## 2 Foreword

### 2.1 Notes on the documentation

#### Copyright

© Beckhoff Automation GmbH & Co. KG, Germany.

The reproduction, distribution and utilization of this document as well as the communication of its contents to others without express authorization are prohibited.

Offenders will be held liable for the payment of damages. All rights reserved in the event of the grant of a patent, utility model or design.

#### Disclaimer

The documentation has been prepared with care. The products described are, however, constantly under development.

We reserve the right to revise and change the documentation at any time and without prior announcement.

No claims for the modification of products that have already been supplied may be made on the basis of the data, diagrams and descriptions in this documentation.

#### Trademarks

Beckhoff®, TwinCAT®, TwinCAT/BSD®, TC/BSD®, EtherCAT®, EtherCAT G®, EtherCAT G10®, EtherCAT P®, Safety over EtherCAT®, TwinSAFE®, XFC®, XTS® and XPlanar® are registered trademarks of and licensed by Beckhoff Automation GmbH. Other designations used in this publication may be trademarks whose use by third parties for their own purposes could violate the rights of the owners.

#### Patent Pending

The EtherCAT Technology is covered, including but not limited to the following patent applications and patents: EP1590927, EP1789857, EP1456722, EP2137893, DE102015105702 with corresponding applications or registrations in various other countries.

#### Intended audience

This description is only intended for the use of trained specialists in control and automation engineering who are familiar with the applicable national standards.

It is essential that the documentation and the following notes and explanations are followed when installing and commissioning these components.

The qualified personnel is obliged to always use the currently valid documentation.

The responsible staff must ensure that the application or use of the products described satisfy all the requirements for safety, including all the relevant laws, regulations, guidelines and standards.

## 2.2 Safety instructions

### Description of instructions

In this documentation the following instructions are used.  
These instructions must be read carefully and followed without fail!

#### **DANGER**

##### **Serious risk of injury!**

Failure to follow this safety instruction directly endangers the life and health of persons.

#### **WARNING**

##### **Risk of injury!**

Failure to follow this safety instruction endangers the life and health of persons.

#### **CAUTION**

##### **Personal injuries!**

Failure to follow this safety instruction can lead to injuries to persons.

#### **NOTICE**

##### **Damage to environment/equipment or data loss**

Failure to follow this instruction can lead to environmental damage, equipment damage or data loss.



#### **Tip or pointer**

This symbol indicates information that contributes to better understanding.

### Intended use

This device is designed for installation in a housing and is intended for general professional use, for example in industrial control systems or office, communication and measuring equipment.

Do not use this power supply in installations where a malfunction could cause serious injury or danger to human life.

### Exclusion of liability

All the components are supplied in particular hardware and software configurations appropriate for the application. Modifications to hardware or software configurations other than those described in the documentation are not permitted, and nullify the liability of Beckhoff Automation GmbH & Co. KG.

### Personnel qualification

This description is only intended for trained specialists in control, automation and drive engineering who are familiar with the applicable national standards.

### Safety regulations

Please note the following safety instructions and explanations!  
Product-specific safety instructions can be found on following pages or in the areas mounting, wiring, commissioning etc.

**Safety information/installation requirements for PS9011-2420-0001 Buffer Module****⚠ DANGER****Danger of electric shock, fire, injuries, injuries resulting in death!**

- Switch off the power supply before working on the device. Provide protection against unintentional reconnection.
- Do not modify or attempt to repair the device.
- Do not open the device, as high voltages are present inside.
- Avoid foreign bodies entering the housing.
- Do not use the device in damp locations or in areas where moisture or condensation is likely to occur.
- Do not touch the device when it is switched on or immediately after it has been switched off. Hot surfaces can cause burns.

**i Further notes on installation requirements**

- This device contains no parts that require maintenance. If an internal fuse trips, this is due to an internal defect.
- If any damage or malfunction occurs during installation or operation, turn off the power supply immediately and return the device to the factory for inspection.
- Install the device in a housing that provides protection against electrical, mechanical and fire hazards.
- Mount the device on a DIN rail according to EN 60715 with the power terminals on the top side of the device.
- Make sure that the wiring is correct by complying with all local and national regulations. Use suitable copper cables designed for a minimum operating temperature of 60 °C at ambient temperatures up to +45 °C, 75 °C at ambient temperatures up to +60 °C and 90 °C at ambient temperatures up to +70 °C. Make sure that all individual wires of a strand are inside the terminal connection.
- The device is designed for areas with a degree of pollution 2 in controlled environments. No condensation or frost is allowed.
- The device housing offers IP20 protection. The housing offers no protection against spilled liquids.
- The insulation of the devices is designed such that it can withstand pulse voltages up to 1.5 kV in accordance with IEC 60664-1.
- The device can be supplied from a regulated power supply or a similar DC voltage source. The continuous voltage between the supply voltage terminals and the PE potential may not exceed 60 Vdc. Use a correspondingly dimensioned 24 V power supply unit that can supply the additional internal current consumption required to charge the capacitors. Pay attention to the correct polarity of the supply voltage. The device does not work if the voltage polarity is reversed. The device must be supplied from a PELV or SELV source or an "isolated secondary circuit" in order to guarantee a SELV or PELV level.
- If the buffer module is connected to a DC source that can supply a continuous current of more than 80 A, a 50 A or 63 A circuit breaker with a B or C characteristic must be connected between the DC source and the buffer module.
- The device is designed for convection cooling and does not require an external fan. Do not obstruct the air flow or cover the ventilation grille!
- Observe the following minimum installation distances: 40 mm above, 20 mm below, 0 mm left and right.
- The device is designed for altitudes of up to 5000 m.
- The maximum temperature of the ambient air is +70 °C (+158 °F). The operating temperature corresponds to the ambient air temperature and is defined 2 cm below the device.
- The device is designed for operation in the relative humidity range between 5 % and 95 %.
- For EMC reasons the signal cables (ready, active, inactive) must be shorter than 30 m.



## 2.3 Terminology and abbreviations

<b>Power supply mode</b>	Describes a state in which the supply voltage lies in the range of the nominal supply voltage and the supplying power supply unit can supply a sufficient amount of current for the buffer module and the load. The mode can also be called "normal mode".
<b>Buffer operation</b>	Describes a state in which the input voltage lies below the transition threshold value, the device is running on capacitors (buffering) and the output is loaded within the permissible limits. The mode can also be called "capacitor mode".
<b>Inhibit mode</b>	Describes a state in which the buffering is deliberately disabled (e.g. for service work).
<b>T.b.d.</b>	Still to be defined, value or description will follow in due course.
<b>DC 24 V</b>	A value preceded by "AC" or "DC" represents a nominal voltage that contains standard tolerances.  Example: DC 12 V refers to a 12 V battery, regardless of whether it is fully charged (13.7 Vdc) or discharged (10 Vdc).
<b>24 Vdc</b>	A value followed by the unit Vac or Vdc is an instantaneous value that does not contain any additional tolerances.
<b>may</b>	A keyword indicating a choice without implied preference.
<b>shall</b>	A keyword indicating a mandatory requirement.
<b>should</b>	A keyword indicating a choice with a clearly preferred method of implementation.

### 3 Basics

#### Principle of operation

If the power supply unit supplies sufficient voltage, the buffer module stores energy in the integrated electrolytic capacitors. In case of a voltage drop or failure, this energy is fed to the DC link in a controlled manner.

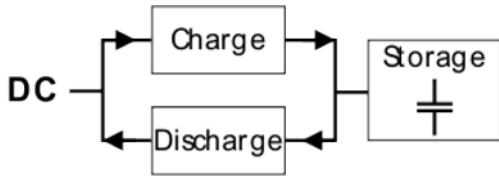

Fig. 1: Functional principle of the buffer module

#### Bridges power faults without interruption

Statistics show that 80% of all power faults last less than 0.2 s. These power faults are fully bridged by the buffer unit. This increases the reliability of the complete system.

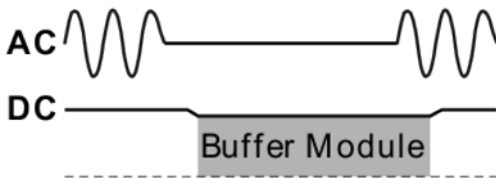

Fig. 2: Bridging power failures

#### Extended hold-up time

Following a power failure or a power cut, the buffer unit maintains the load current for a defined timespan. Process data can be saved and processes ended before the DC voltage is switched off. A controlled restart is then possible.

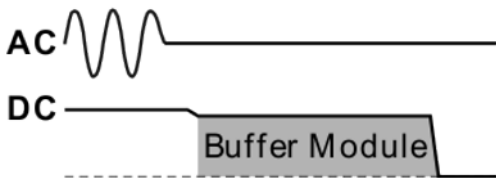

Fig. 3: Extended buffer time in case of a power failure

#### Simple to handle, extendable and maintenance-free

The buffer module requires no control wiring. It can be inserted anywhere in parallel with the load circuit. Buffer modules can be connected in parallel in order to increase the output current capacity or the hold-up time.

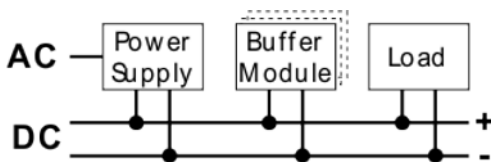

Fig. 4: Parallel connection without control wiring

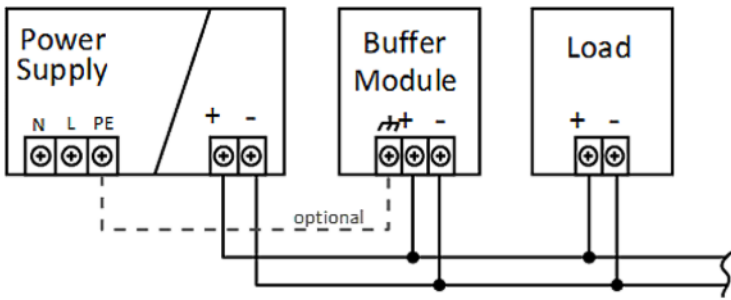

Fig. 5: Typical wiring

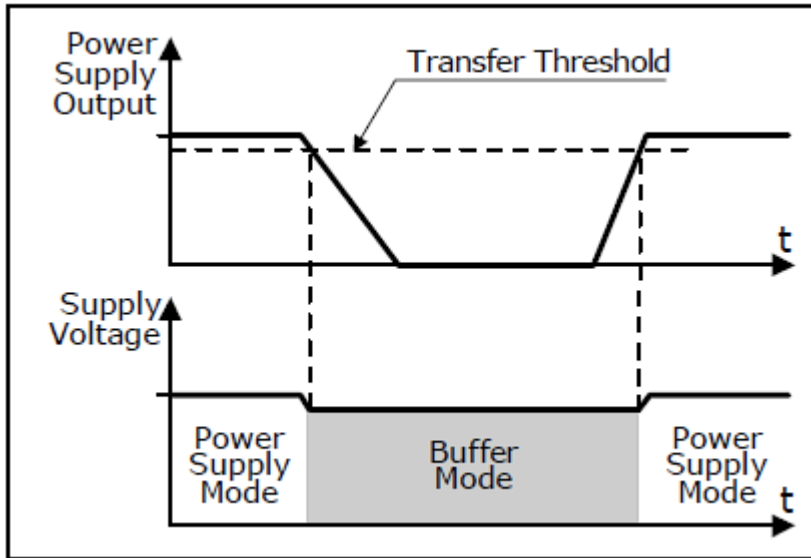

Fig. 6: Transition behavior

## 4 Technical data, application notes, wiring

### 4.1 Nominal electrical values

Electrical parameters			
Supply voltage	Nom.	DC 24V	-20%/+25%
Supply voltage range <sup>1)</sup>	Nom.	19.2 - 30 Vdc	
Normal operating voltage range <sup>2)</sup>	Typ.	23 – 30 Vdc	
Transition voltage for switching to buffer mode	Typ.	22.5 Vdc	Backup threshold value jumper set to "22.5 V fixed"
	Typ.	$V_{IN} - 1 V$	Backup threshold value jumper set to " $V_{IN} - 1 V$ " (Refer also to the chapter "Selection of the backup threshold voltage" [▶ 14]).
Transition voltage for switching from buffer mode to supply mode	Typ.	22.5 Vdc	Backup threshold value jumper set to "22.5 V fixed"
	Typ.	$V_{BUFFER} + 1 V$	Backup threshold value jumper set to " $V_{IN} - 1 V$ " (Refer also to the chapter "Selection of the backup threshold voltage" [▶ 14]).
Buffer voltage	Typ.	Equal to the transition voltage for switching to buffer mode.	
Residual ripple and noise voltage - in buffer mode - in power supply mode	Max.	200mVpp	Generated by the buffer module. (defined at 20 Hz to 20 MHz, 50 Ohm)
		The residual ripple and noise voltage are defined by the power supply.	
Current consumption	Typ.	80 mA	When the capacitor is fully charged
	Min.	400 mA	During the charging of the capacitors
	Max.	600 mA	During the charging of the capacitors
Power loss	Typ.	1.9W	When the capacitor is fully charged
Buffer current	Min.	40A	
Buffer current overload behavior		Electronically limited, buffering stops and capacitor is discharged under 17 V. See fig. "Output characteristic curve in buffer mode, 22.5 V fixed mode, typ."	
Permissible voltage between supply voltage and housing ground	Max.	60 Vdc or 42.4 Vac	Continuous operation, IEC 62477-1
Capacitive and inductive loads		no limit	

<sup>1)</sup> Supply voltage range:

At voltages within the input voltage range, the control functions such as LEDs, monitoring functions, relay contacts, etc. function as normal. Within the input voltage range the device can either be in power supply mode or buffer mode.

<sup>2)</sup> Normal operating voltage range:

The normal operating voltage range describes the supply voltage that supports the full functionality of the buffer module (including charging) without entering buffer mode.

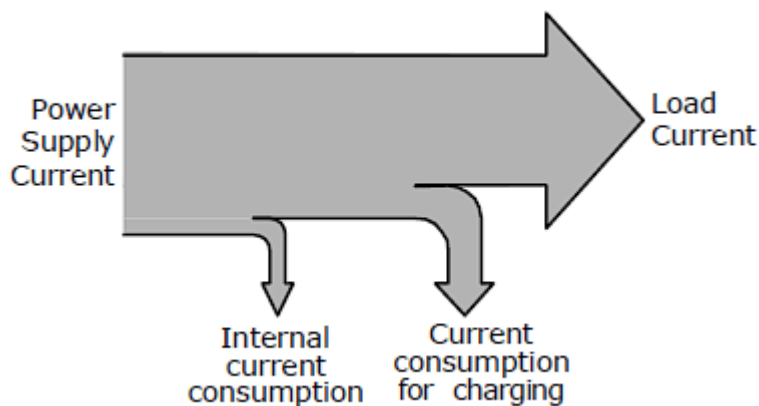

Fig. 7: Selection of a suitable power supply

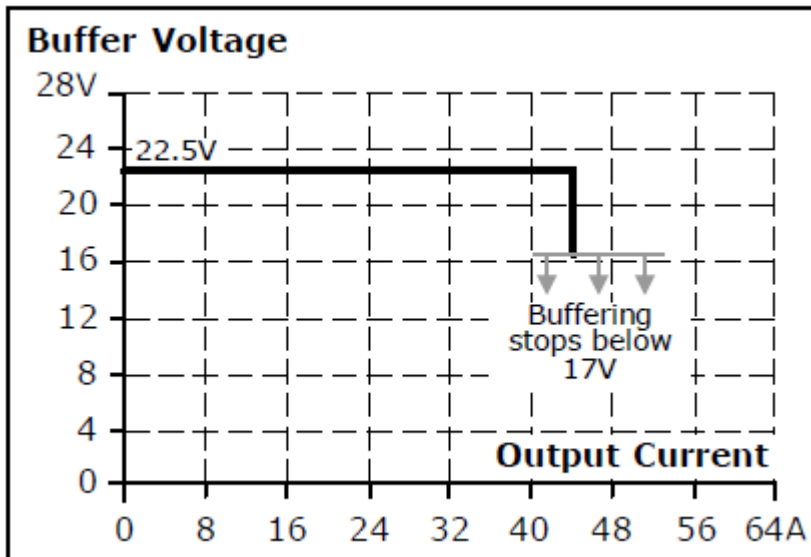

Fig. 8: Output characteristic curve in buffer mode, 22.5 V fixed mode, typ.

## 4.2 Selection of the backup threshold voltage

The buffer behavior – "Fixed Mode" or "Variable Mode" – can be selected with the backup jumper.

**Fixed mode:** (jumper in position "2-3" or "22.5 V fixed")

If the supply output voltage falls below 22.5 V, buffering begins and the supply voltage is maintained at this level.

This setting is recommended:

- if power supplies other than the PS3xxx series are used
- with back-feeding loads
- if the buffer module is placed close to the load or
- in case of doubt.

**Variable mode:** (jumper in position "1-2" or "VIN – 1 V")

Buffering begins if the supply voltage drops by more than 1 V. Buffering ends if the supply voltage increases by more than 1 V.

Voltage changes slower than 0.54 V/s are ignored if the voltage is above 22.5 V. Buffering begins immediately below 22.5 V.

This setting is recommended for all applications in which 22.5 V is too low for the application or if the buffer module is placed near the power supply.

The factory setting is fixed mode; if the jumper is missing, this also means fixed mode.

### 4.3 Buffer storage time

The buffer time (sometimes also called autonomy time) is the maximum timespan over which the capacitor can maintain the required output current. The buffer time mainly depends on the output current in buffer operation.

Any number of buffer modules can be connected in parallel in order to increase the buffer time.

Buffer time	Min.	160 ms	At 22.5 V, 40 A
	Min.	320 ms	At 22.5 V, 20 A
	Typ.	250 ms	At 22.5 V, 40 A
	Typ.	500 ms	At 22.5 V, 20 A
	Typ.	62 s	At 22.5 V, 0.1 A

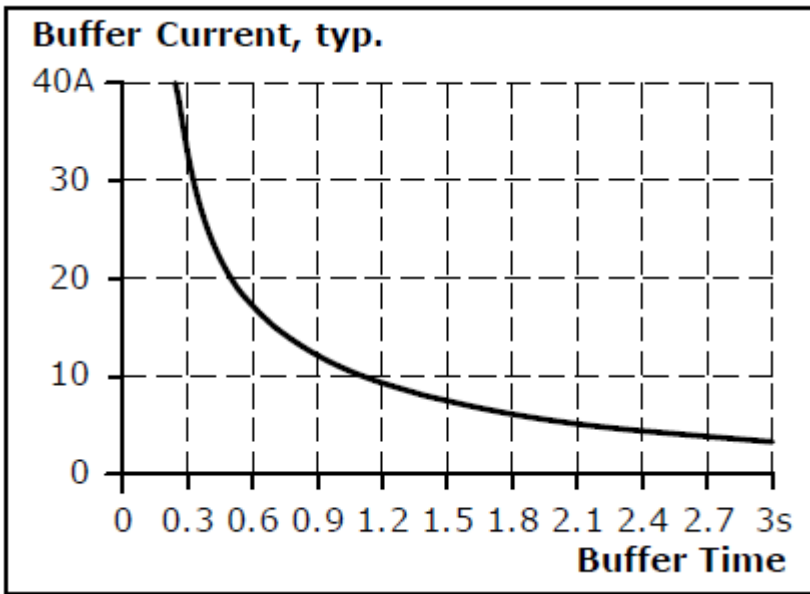

Fig. 9: Buffer time, typ.

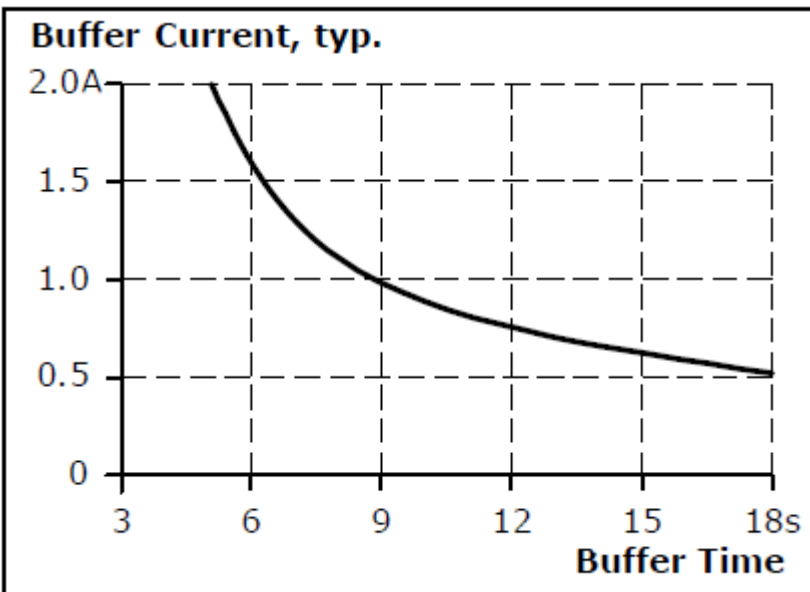

Fig. 10: Buffer time for low buffer currents, typ.

## 4.4 Charging time

The charging of the internal capacitors is indicated by the Status LED, which flashes at a low frequency (1.25 Hz).

Charging time	Min.	29 s	Initial charging <sup>1)</sup>
	max	50 s	Initial charging <sup>1)</sup>
	min	24 s	Recharging <sup>2)</sup>
	max	40 s	Recharging <sup>2)</sup>

<sup>1)</sup> Initial charging is the first charging after applying the voltage to the buffer module.

<sup>2)</sup> Recharging is the charging of the internal capacitors after voltage interruptions lasting less than 2 minutes.

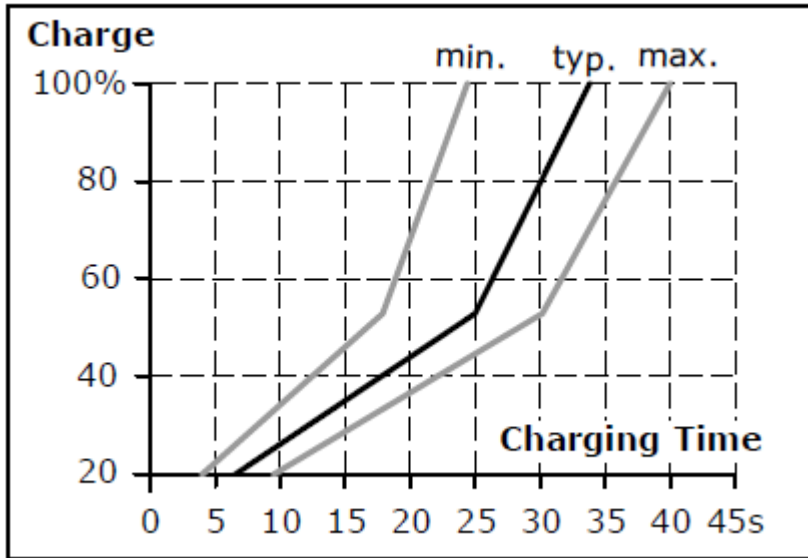

Fig. 11: Charging time, recharging



### 4.5 Operating diagrams

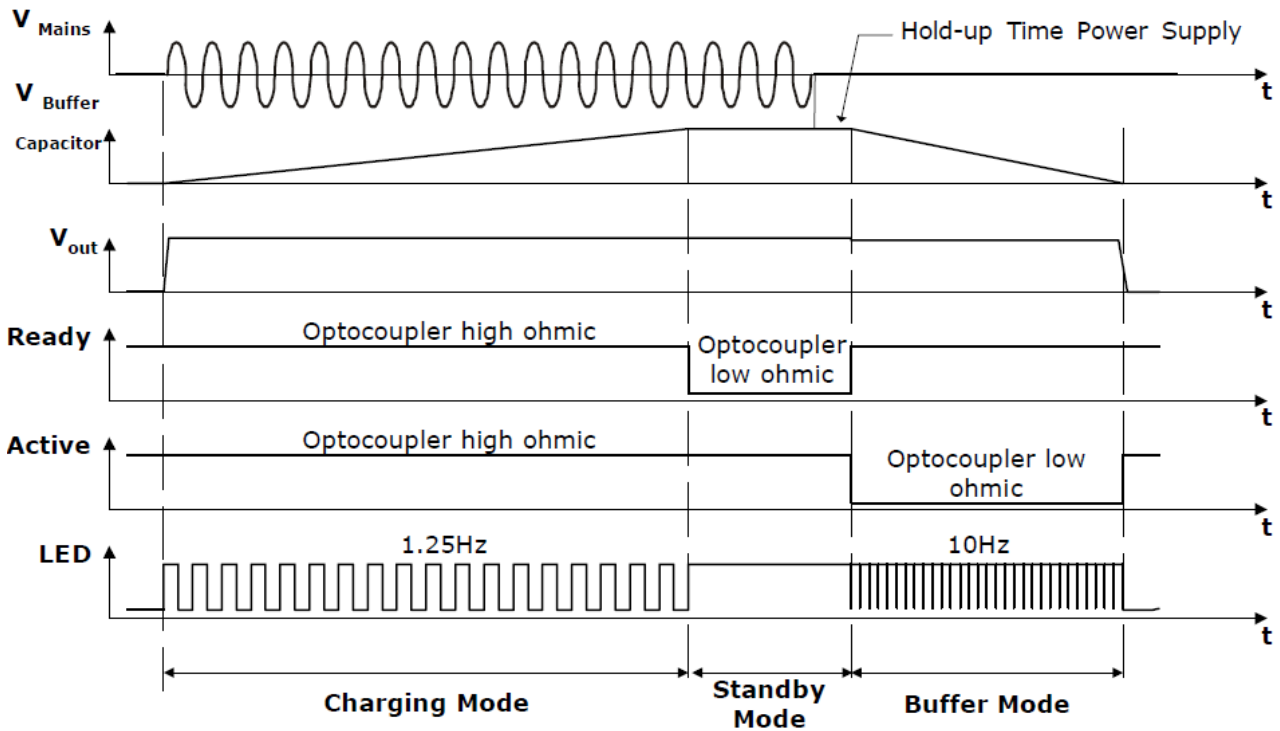

Fig. 12: Operating diagram

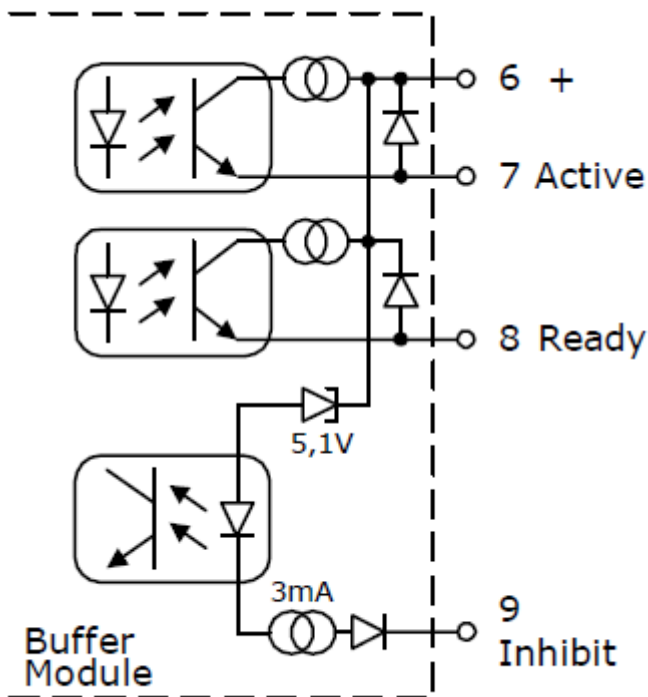

Fig. 13: Signal circuit diagram

## 4.6 "Active" signal

The "Active" signal (pin 7) is an optocoupler output that has a low resistance during the discharging of the buffer capacitors.

For a connection schematic, refer to the illustrations in the chapter [Operating diagrams \[► 17\]](#) and [Connection diagrams \[► 20\]](#).

Signal voltage	Max.	35 Vdc	Voltage between pins 6 and 7
Signal current	Max.	10 mA	
Voltage drop across optocoupler		0.9 V / 3 V	At 1 mA / 5 mA while optocoupler has a low resistance
Leakage current	Max.	50 µA	While optocoupler has a high resistance
Insulation voltage	See chapter <a href="#">Dielectric strength [► 23]</a>		

## 4.7 "Ready" signal

The "Ready" signal (pin 8) is an optocoupler output that has a low resistance when the buffer capacitors are fully charged.

For a connection schematic, refer to the illustrations in the chapter [Operating diagrams \[► 17\]](#) and [Connection diagrams \[► 20\]](#).

Signal voltage	Max.	35 Vdc	Voltage between pins 6 and 8
Signal current	Max.	10 mA	
Voltage drop across optocoupler		0.9 V / 3 V	At 1 mA / 5 mA while optocoupler has a low resistance
Leakage current	Max.	50 µA	While optocoupler has a high resistance
Insulation voltage	See chapter <a href="#">Dielectric strength [► 23]</a>		

## 4.8 Inhibit input

The buffering can be inhibited or interrupted with the inhibit input (pin 9). To do this, pin 6 must be connected to the positive pole of the terminal voltage or to the external control voltage and pin 9 must be connected to the corresponding negative pole.

The inhibition of the device also results in the discharging of the internal capacitors. The capacitors cannot be charged as long as the buffer module is in inhibit mode.

For a connection schematic, refer to the illustrations in the chapter [Operating diagrams \[► 17\]](#) and [Connection diagrams \[► 20\]](#).

Signal voltage	Max.	35 Vdc	Voltage between pins 6 and 9
Signal current	Max.	4 mA	Current limited
Inhibit mode	The device does not buffer (or stops buffering) if the voltage between pin 6 and pin 9 is higher than 10 V. The buffering functions again below 6 V.		
Insulation voltage	See chapter <a href="#">Dielectric strength [► 23]</a>		

## 4.9 Efficiency and losses

Efficiency	Typ.	>99%	Power supply mode, 40 A output current, capacitors fully charged
Power losses	Typ.	1.9W	Power supply mode, 0 A output current, capacitors fully charged

## 4.10 Lifetime expectancy

The lifetime expectancy shown in the table indicates the minimum number of operating hours (service life) and is determined by the lifetime expectancy of the built-in electrolytic capacitors. The lifetime expectancy is stated in operating hours and is calculated according to the specifications of the capacitor manufacturer. The manufacturer of the electrolytic capacitors only guarantees a maximum life of up to 15 years (131,400h). Any number exceeding this value represents a calculated theoretical service life which can be used to compare devices.

Calculated lifetime expectancy	189,000h	Standby mode, 40 °C
	536,000h	Standby mode, 25 °C

## 4.11 MTBF

MTBF stands for **Mean Time Between Failure**, which is calculated from the statistical failure rate of the components and indicates the reliability of a device. It is a statistical representation of the probability of equipment failure and does not necessarily represent the service life of a product.

The MTBF number is a statistical representation of the probability of equipment failure. An MTBF number of 1,000,000h, for example, means that statistically, if there are 10,000 devices in use, one device will fail every 100 hours. However, it is not possible to say whether the failed device has been in operation for 50,000 hours or only 100 hours.

For these device types the MTTF value (**Mean Time To Failure**) is identical to the MTBF value.

MTBF SN 29500, IEC 61709	2,114,000h	Standby mode, 40 °C
	3,937,000h	Standby mode, 25 °C
MTBF MIL HDBK 217F	272,000h	Standby mode, 40 °C, Ground Benign GB40
	433,000h	Standby mode, 25 °C, Ground Benign GB25
	95,000h	Standby mode, 40 °C, Ground Fixed GF40
	143,000h	Standby mode, 25 °C Ground Fixed GF25

## 4.12 Functional wiring diagram

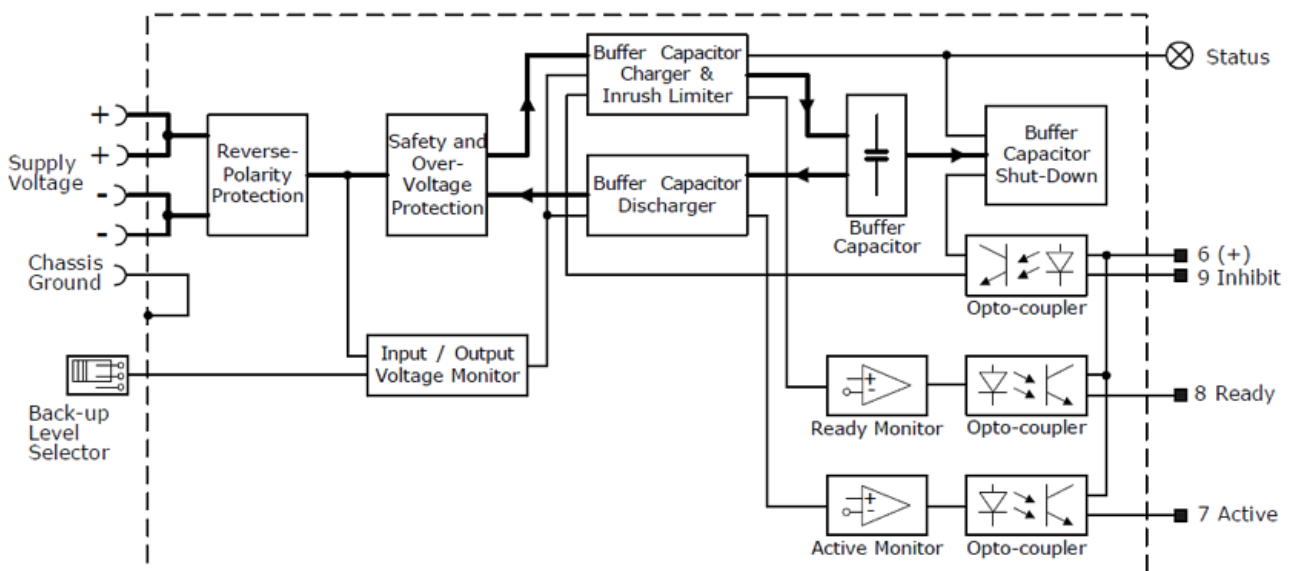

Fig. 14: Functional wiring diagram

### 4.13 Terminals and wiring

The terminals are designed to be finger-safe according to IP20 and are suitable for field or factory wiring.

	Supply voltage, housing ground	Signal
Type	Screw terminals	Pluggable screw terminals
Connection cross-section	e*: max. 16mm <sup>2</sup> f*: max. 10mm <sup>2</sup> a*: max 10mm <sup>2</sup> (d<5.2mm)	e*: max. 2.5mm <sup>2</sup> f*: max. 2.5mm <sup>2</sup> a*: max. 2.5mm <sup>2</sup> (d<2.25mm)
Connection cross section (AWG)	e*: AWG 22-8 f*: AWG 22-8 a* AWG 22-8	e*: AWG 22-14 f*: AWG 22-14 a*: AWG 22-14
Strip length	12mm	6mm

e\* = solid wire  
f\* = stranded wire  
a\* = with ferrule

### 4.14 Connection diagrams

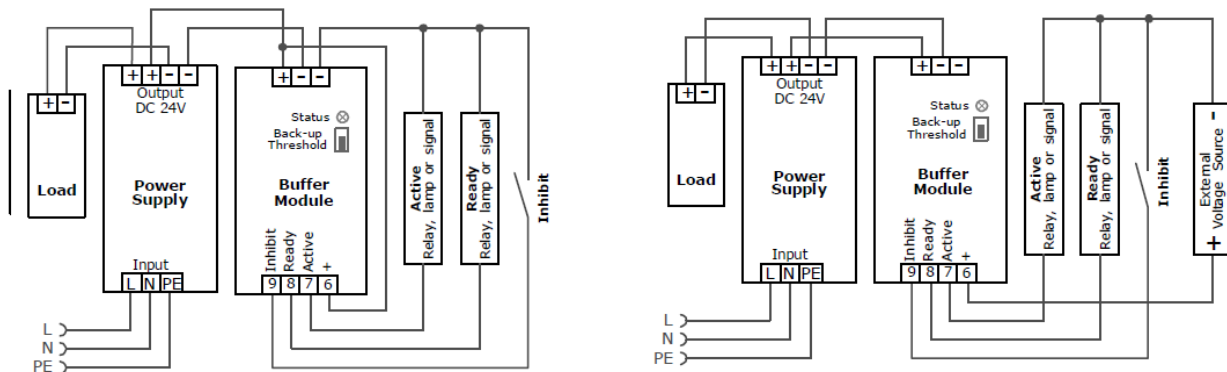

Fig. 15: General connection diagrams; signals that are supplied by an external voltage source

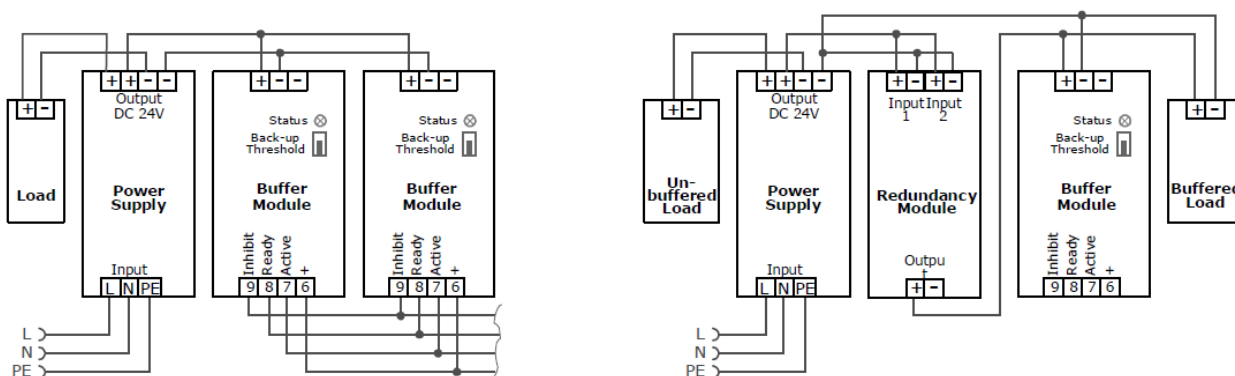

Fig. 16: Parallel connection of buffer modules; decoupling of buffered lines

## 4.15 Front side and operating elements

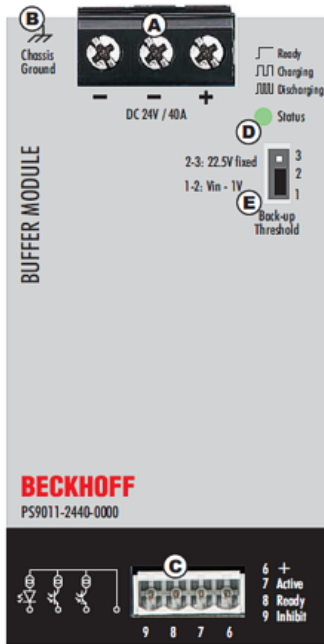

Fig. 17: Front PS9011-2440-0000

### Supply voltage terminals (screw terminals)

Designation (A)	Description
+	Positive supply voltage terminal (1x)
-	Negative (back) supply voltage terminal (2x)

### Chassis ground terminal (ring terminal)

Designation (B)	Description
chassis ground	Connection to device upper side with a ring terminal, suitable for an M4 screw. The connection of the chassis to the ground (earth) is optional and is only necessary for certain applications.

### Signal connection (4-pin connector with screw connection)

Designation (C)	Description
6 +	- "+" – positive switching output
7 Active	- "Active" signal, for details see chapter <a href="#">Active signal [▶ 18]</a>
8 Ready	- "Ready" signal, for details see chapter <a href="#">Ready signal [▶ 18]</a>
9 Inhibit	- "Inhibit" input, for details see chapter <a href="#">Inhibit input [▶ 18]</a>

### Status LED

Designation (D)	Description
LED green	This green LED shows the following information: - OFF: capacitors are discharged or the supply voltage is lower than 22 V. - ON: capacitors are fully charged - Slow flashing (1.25 Hz): capacitors are being charged. - Fast flashing (10 Hz): the capacitors are discharging.

### Backup threshold value jumper

Designation (E)	Description
Backup threshold	- Option 1: Fixed mode (jumper in position 2-3): the device switches to buffer mode as soon as the voltage drops below 22.5 V. - Option 2: Variable mode (jumper in position 1-2): the device switches to buffer mode when the input voltage drops by 1 V. Voltage changes slower than 0.54 V/s are ignored if the voltage is above 22.5 V. Buffering begins immediately below 22.5 V. For further details, refer also to the chapter <a href="#">Selection of the backup threshold voltage [▶ 14]</a>

## 4.16 EMC

The EMC behavior of the device is designed for applications in industrial environments as well as residential, commercial or small business environments.

The device was tested according to EN 61000-6-1, EN 61000-6-2, EN 61000-6-3 and EN 61000-6-4.

This device meets the requirements according to FCC Part 15. Operation is subject to the following two conditions: (1) This device may not cause harmful interference, and (2) this device must be able to deal with any interference received, including interference that may cause undesired operation.

The signal cables ("Ready", "Active" and "Inhibit") must be shorter than 30 m.

EMC interference immunity			
Fast transients (burst)	EN 61000-4-4	<ul style="list-style-type: none"> <li>• Input cables</li> <li>• Output cables</li> <li>• Signal cables Pin 6, 7, 8, 9 **)</li> </ul>	Criterion A <sup>1)</sup> 2 kV

\*\*) Tested with connecting terminal.

<sup>1)</sup> A: Buffer module exhibits normal operating behavior within the defined limits.

EMC interference emission	For standby and charging mode	
Conducted interference emission, input lines	IEC/CISPR 16-1-2, IEC/CISPR 16-2-1	Limit values for DC power supply connections according to EN 61000-6-3 fulfilled
Interference emission	EN 55011, EN 55022	Class B

Switching frequencies		
Charge converter on 24 V input (is only active during charging)	6 to 610 kHz	The frequency depends on the charge state of the capacitors
Buffer converter when buffering at 22.5 V	10 to 70 kHz	The frequency depends on the output current. The values are valid between 10% and 100% of the nominal buffer current

## 4.17 Environment

Environment		
Operating temperature	-25 °C to + 70 °C	The operating temperature corresponds to the ambient or environmental temperature and is defined as the air temperature 2 cm below the device.
Storage temperature	-40 °C to + 70 °C	For storage and transport
Moisture	5 to 95% r.h.	IEC 60068-2-30
Oscillation, sinusoidal	2–17.8 Hz: ±1.6 mm; 17.8–500Hz: 2g 2 hours/axis	IEC 60068-2-6
Oscillation, any	0.5 m <sup>2</sup> (s <sup>3</sup> ) 2 hours / axis	IEC 60068-2-64
Impact	30g 6ms, 20g 11ms 3 impacts/direction, 18 impacts in total	IEC 60068-2-27
Installation altitude	0 to 6000m	Approvals apply only up to 2000 m
Overvoltage category	III	IEC 62103, EN 62477-1
	II	IEC 62103, EN 62477-1, above an altitude of 2000 m
Degree of pollution	2	IEC 62103, EN 62477-1, not conductive
LABS compatibility	The device does not release any silicone or other LABS-critical substances and is suitable for use in painting plants.	

## 4.18 Protective functions and safety features

Protective functions and safety features		
Insulation resistance	> 500MΩ	In the delivery state between the mains power connection and signals, measured with 500 Vdc
	> 500MΩ	In the delivery state between the mains power connection and the housing, measured with 500 Vdc
	> 500MΩ	In the delivery state between the signal connections and the housing, measured with 500 Vdc
PE resistance	< 0.1 ohm	Resistance between the chassis ground terminal and the housing.
Protection class	N/A	Install the buffer module according to the rules of Class III
Protection class / ingress protection	IP 20	EN/IEC 60529
Overtemperature protection	-	
Output overvoltage protection	Typ. 32Vdc Max. 35Vdc	In the event of a defect in the internal buffer module, a redundant circuit limits the maximum output voltage. The buffering stops and automatically attempts to restart.
Internal input fuse	-	
Overvoltage protection at the input	Max. 35Vdc	Device not damaged or defective
Reverse polarity protection at the input	Max. -35 Vdc	Device not damaged or defective
Touch current (leakage current)	The leakage current generated by the buffer module itself depends on the input voltage ripple and must be investigated in the final application. With an even DC input voltage, the leakage current generated is less than 100 µA.	

## 4.19 Dielectric strength

The output voltage is earth-free and has no ohmic connection to earth.

Type and component tests are carried out by the manufacturer. Field tests can be performed in the field using suitable test equipment that ramps up the voltage with a slow ramp (2s rising and 2s falling). Connect all input terminals and all output poles to each other before performing the tests. During the test, set the cut-off current to the value shown in the table below.

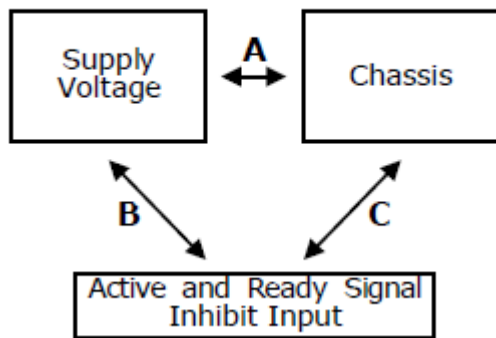





Fig. 18: Dielectric strength

		A	B	C
Type test	60s	500 Vac	500 Vac	500 Vac
Component test	5s	500 Vac	500 Vac	500 Vac
Field test	5s	500 Vac	500 Vac	500 Vac
Settings for the field test cut-off current		> 1 mA	> 1 mA	> 1 mA

## 4.20 Declaration of conformity and approvals

	EU declaration of conformity
	UL Certificate: UL508, Applicable for US and Canada
	UK Declaration of Conformity: Trade conformity assessment for England, Scotland and Wales The UKCA mark indicates conformity with the UK Statutory Instruments 2016 No. 1101 (LVD) 2016 No. 1091 (EMC) and 2012 No. 3032 (RoHS)



## 4.21 Dimensions and weight

Overall width	64mm
Height	124mm
Depth	142mm The height of the DIN rails must be added to the depth of the device to calculate the total installation depth required
Weight	1040g
DIN rail	Use 35 mm DIN rails according to EN 60715 or EN 50022 with a height of 7.5 or 15mm.
Housing material	Housing: Aluminum alloy Cover: galvanized steel
Ingress protection	Small parts such as screws, nuts, etc. with a diameter greater than 3.5 mm
Installation clearances	See chapter on <a href="#">Safety instructions and installation requirements</a> [▶ 8]

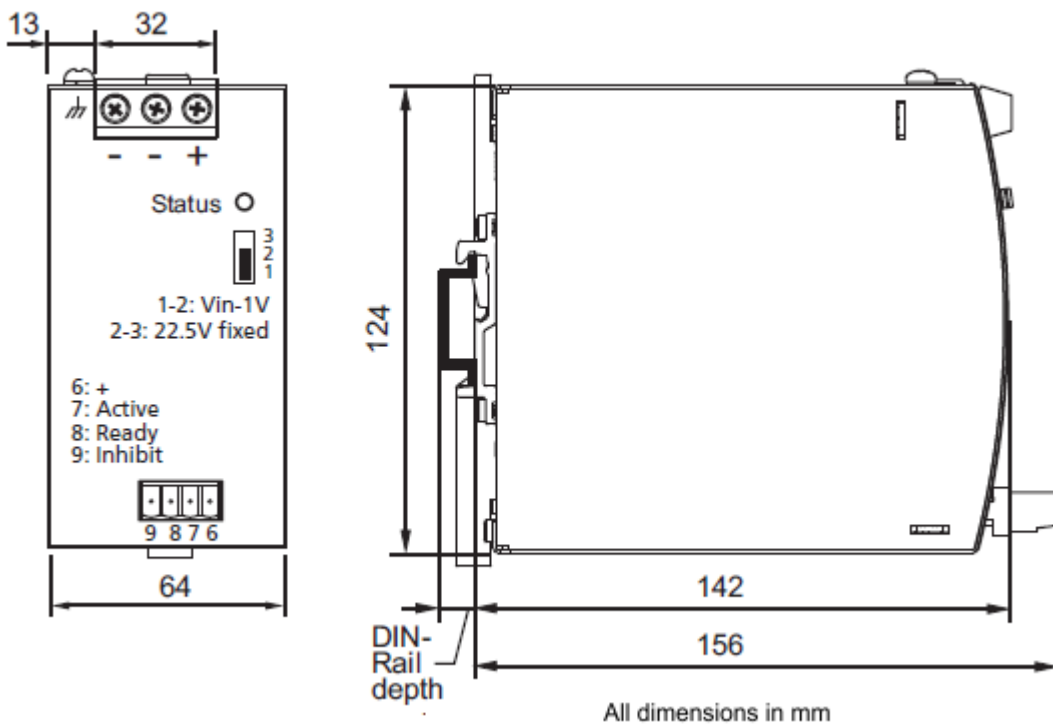

Fig. 19: PS9011-2440-0000 – front/side view

## 5 Appendix

### 5.1 Accessories

#### ZS5301-0002 – Bracket for wall mounting

This bracket is used to mount the devices to a wall or panel without using a DIN rail.

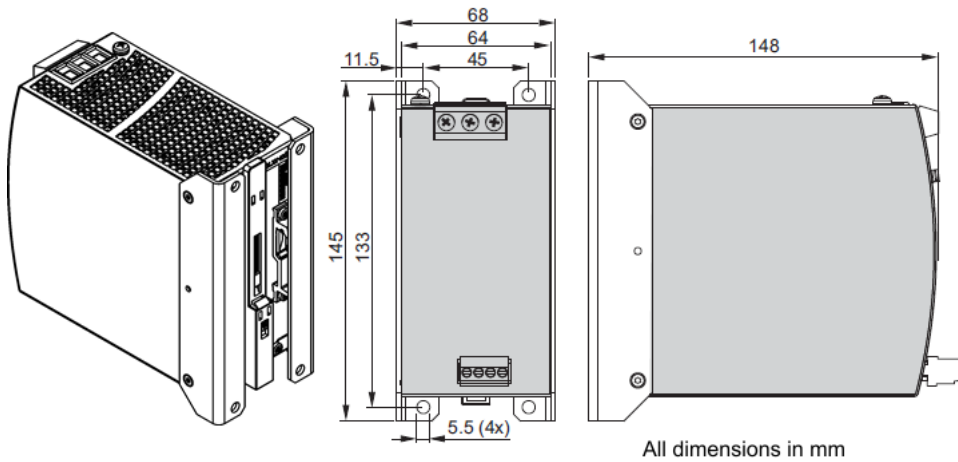

Fig. 20: Isometric view, wall mounting dimensioning, installation dimensions of the brackets for lateral mounting

#### ZS5301-0007 – Bracket for side mounting

This bracket is used in order to mount the devices laterally with or without the use of a DIN rail.

The two aluminum brackets and the black plastic slider of the unit must be removed to allow the steel brackets to be mounted.

For lateral DIN rail mounting, the previously removed aluminum brackets and the black plastic slider must be mounted on the steel bracket.

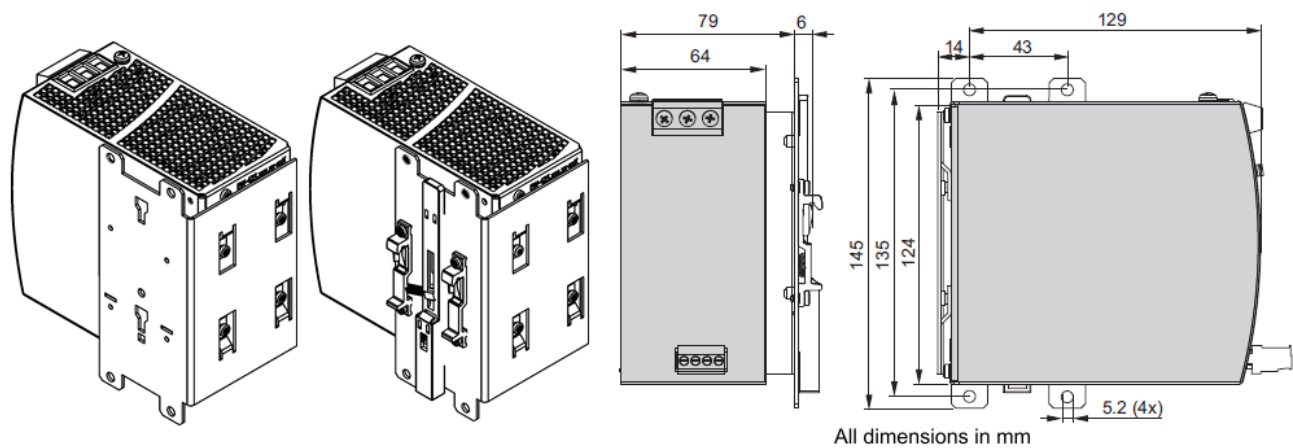

Fig. 21: Isometric view, lateral mounting without and with DIN rail bracket; mounting dimensions

## 5.2 Documentation issue status

Version	Comment
1.0	- Addenda & corrections - 1 <sup>st</sup> public issue
0.2	- Addenda & corrections
0.1	- Preliminary documentation for PS9011-2440-0000

## 5.3 Support and Service

Beckhoff and their partners around the world offer comprehensive support and service, making available fast and competent assistance with all questions related to Beckhoff products and system solutions.

### Beckhoff's branch offices and representatives

Please contact your Beckhoff branch office or representative for local support and service on Beckhoff products!

The addresses of Beckhoff's branch offices and representatives round the world can be found on her internet pages: [www.beckhoff.com](http://www.beckhoff.com)

You will also find further documentation for Beckhoff components there.

### Support

The Beckhoff Support offers you comprehensive technical assistance, helping you not only with the application of individual Beckhoff products, but also with other, wide-ranging services:

- support
- design, programming and commissioning of complex automation systems
- and extensive training program for Beckhoff system components

Hotline: +49 5246 963 157  
e-mail: [support@beckhoff.com](mailto:support@beckhoff.com)  
web: [www.beckhoff.com/support](http://www.beckhoff.com/support)

### Service

The Beckhoff Service Center supports you in all matters of after-sales service:

- on-site service
- repair service
- spare parts service
- hotline service

Hotline: +49 5246 963 460  
e-mail: [service@beckhoff.com](mailto:service@beckhoff.com)  
web: [www.beckhoff.com/service](http://www.beckhoff.com/service)

### Headquarters Germany

Beckhoff Automation GmbH & Co. KG

Hülshorstweg 20  
33415 Verl  
Germany

Phone: +49 5246 963 0  
e-mail: [info@beckhoff.com](mailto:info@beckhoff.com)  
web: [www.beckhoff.com](http://www.beckhoff.com)



More Information:

[www.beckhoff.com/ps9011-2440-0000](http://www.beckhoff.com/ps9011-2440-0000)

Beckhoff Automation GmbH & Co. KG  
Hülshorstweg 20  
33415 Verl  
Germany  
Phone: +49 5246 9630  
[info@beckhoff.com](mailto:info@beckhoff.com)  
[www.beckhoff.com](http://www.beckhoff.com)

